

Wooden Tractor: 3

Tractor Chassis

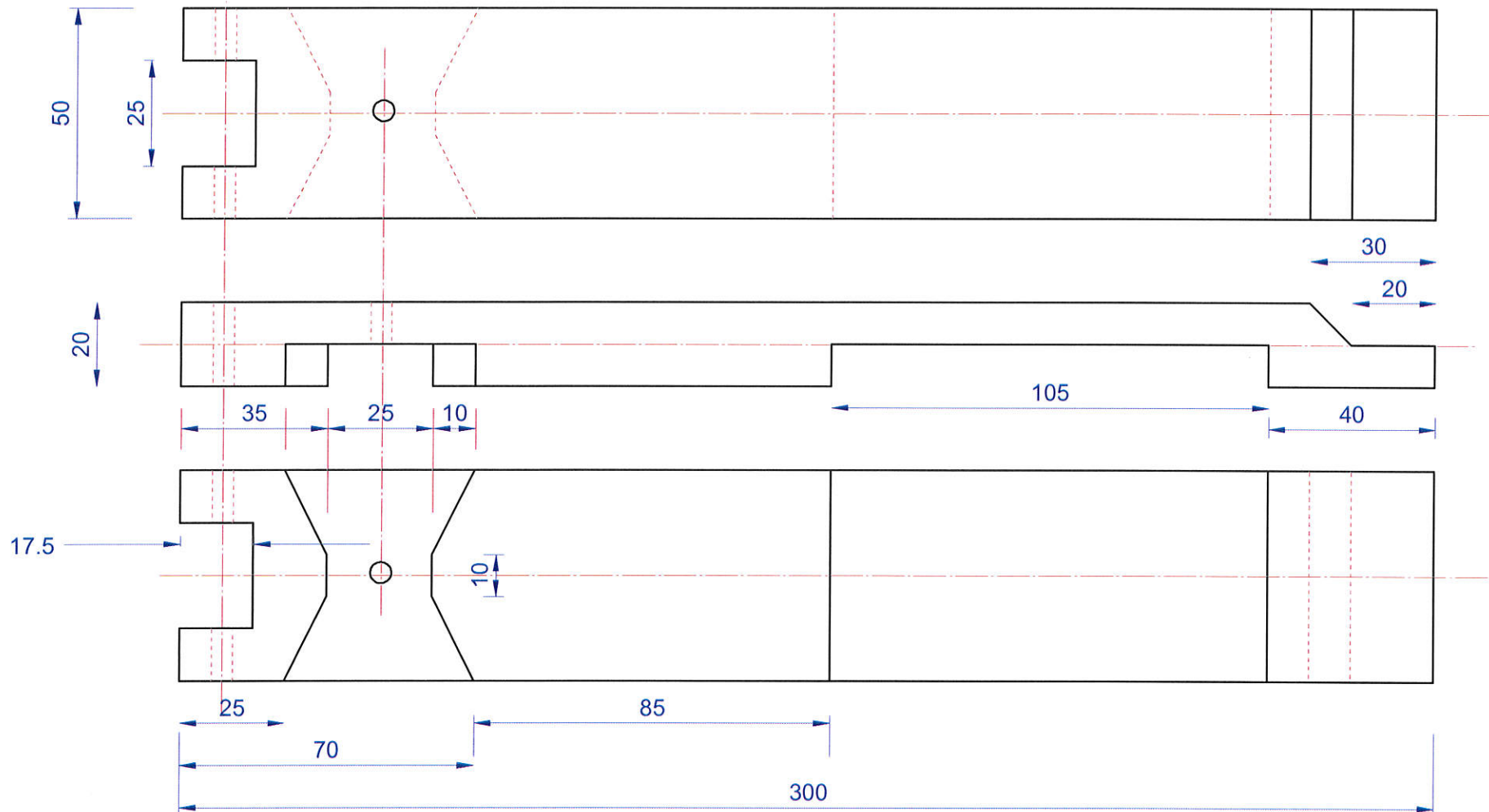

Mark Elwell
Designed By ME Consultancy Ltd.

Wooden Tractor: 2

Rear Axel Block

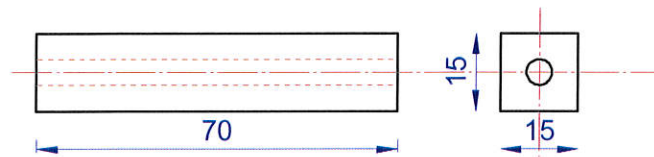

Front Axel Block

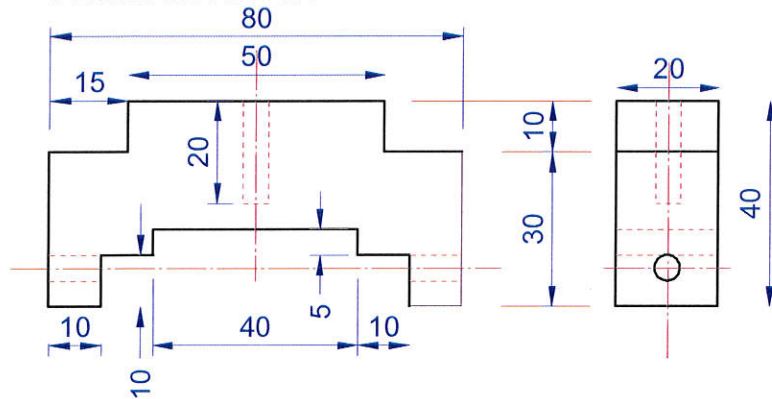

Cab Sides

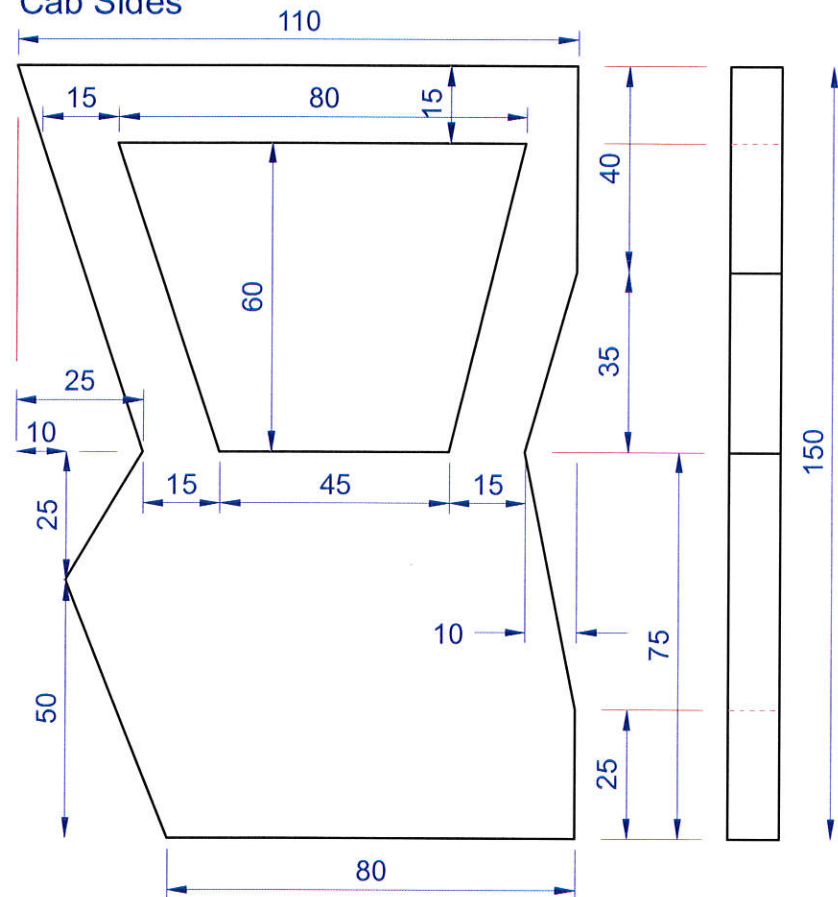

Wooden Tractor: 1

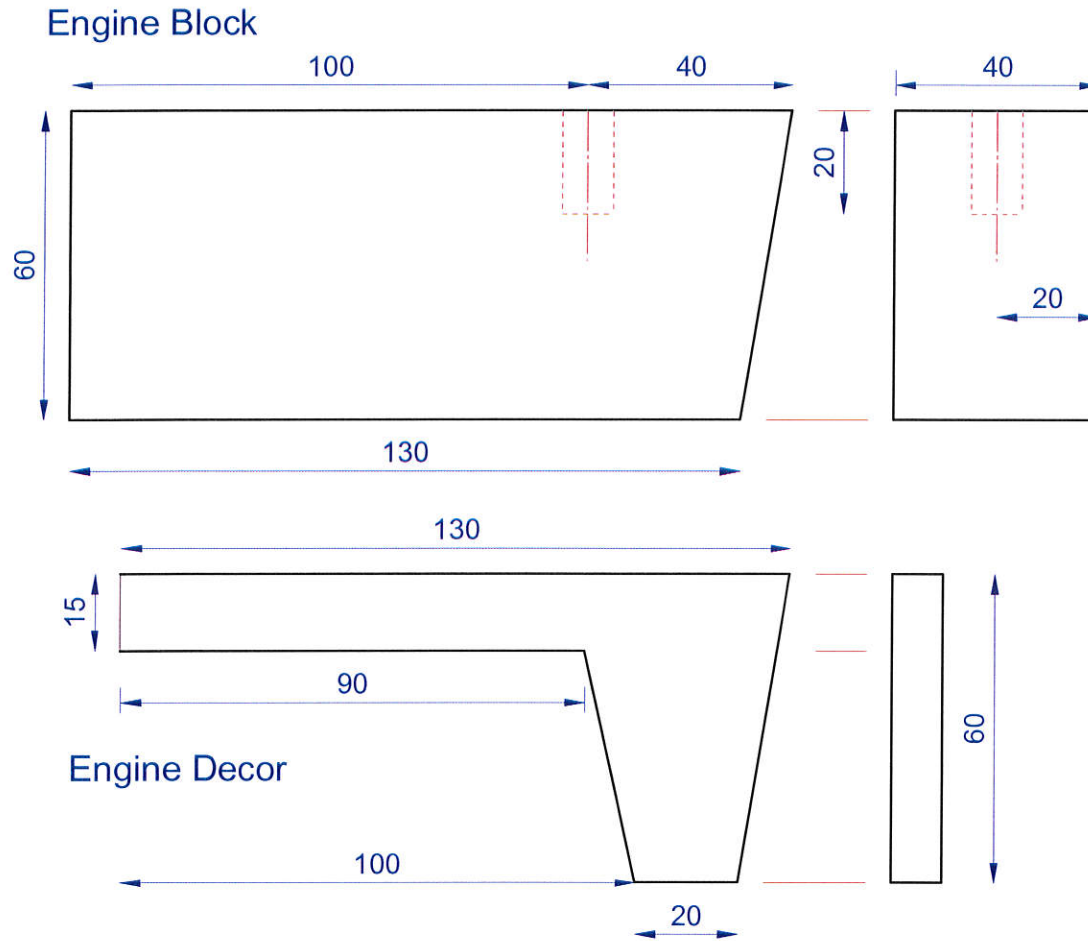

Cab Roof:
140 x 110 x 9mm MDF

Cab Base:
105 x 90 x 9mm MDF

Mark Elwell
Designed By ME Consultancy Ltd.

Wheel Arches

